

**Vertical  
submerged**

**balanced  
thrust**

**heavy duty  
pumps**

**VCRO**

**open impeller  
pumps  
for clear liquids  
and light slurries**

**SIMPLEX AND DUPLEX  
MODELS**



# VCRO balanced thrust pumps reliable for tank and pit service

## DESIGN/CONSTRUCTION

**CASING** - end suction • balanced axial and radial thrust • vertically split • center line discharge • self venting • top pullout • quick release locking lugs • 150 psi flat face or 300 psi flat face discharge flanges.

**CASING COVER** - confined gasket at casing • rabbeted alignment.

**IMPELLER** - open type • high efficiency • statically and hydraulically balanced • low submergence • enclosed impellers available.

**PUMP GUIDE BEARING** - located in casing cover • carbon graphite standard • rubber and other materials available • lubricated by pumped liquid or external source.

**INTERMEDIATE GUIDE BEARING** - located in connecting column • required for sump depths greater than nominal 6 feet • materials and lubrication same as pump guide bearing.

**CONNECTING COLUMN** - rigid flange with Schedule 40 steel pipe (or equivalent stainless steel weldment) • integrally mounted with thrust cartridge and casing cover to provide accurate alignment.

**THRUST BEARING** - double row angular contact ball • 150,000 hours average life • grease lubricated • cartridge provides external impeller clearance adjustment without disturbing pump end • located at cover or elevated.

**SHAFT** - cold rolled steel • polished and ground for intermediate bearings • steel or stainless to complement pump end.

**STUFFING BOX** - grease lube lip seals • packing • mechanical seals • located in integral thrust bearing housing • positive bearing-pump end alignment.

**COVER PLATE** - rectangular or round • steel or stainless • single or duplex • vented • gas tight • manhole.

**CONTROLS** - float switch • mechanical and electrical alternators • high-water alarm • floatless electrode.

**STRAINERS** - stainless • sized to meet solids capability of pump end and to optimize inlet velocities.

**MOTOR STAND** - standard for P-base motors • C-face and D-flange motors optional.

## 4-WAY PUMP INTERCHANGEABILITY

The VCRO is one of Buffalo's 4-Way Pumps, a line which includes the Buffalo Can-O-Matic, Frame Mounted and Close-Coupled designs. This means the same wet end parts... casings, casing covers, impellers and wearing rings... are common throughout the 4-Way Pump line. All VCRO parts are available from factory stock.

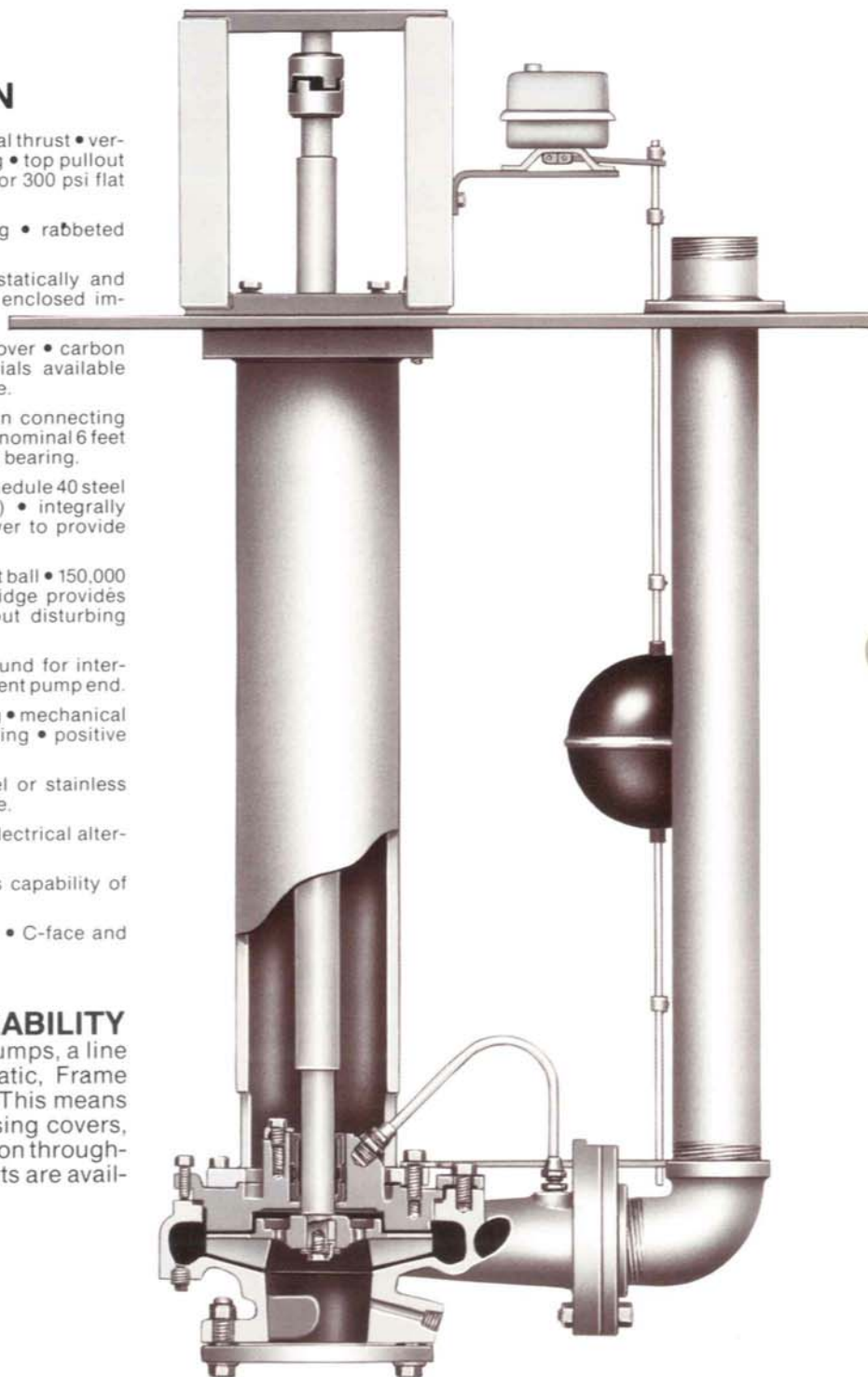

Copyright 1982

# VCRO balanced thrust pumps model configurations/controls



VCRO Simplex Model  
with intermediate bearing

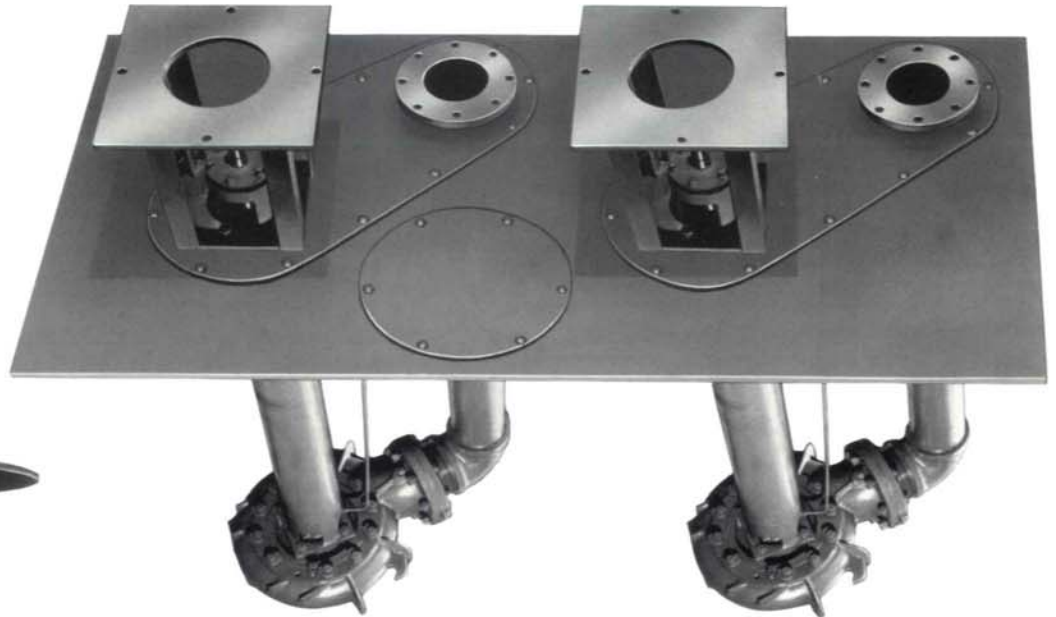

VCRO Duplex Model  
with separate mounting plates and manhole on common pitcover.

Buffalo VCRO Pumps are available in simplex and duplex configurations. Several control systems are available to meet your operating conditions. They include: float switches, mechanical alternators, electrical alternators, float and displacement type liquid level sensors and alarm systems. Your Buffalo Sales Engineer can help you select the correct control package for your applications.



VCRE Short-Coupled Model  
Features foot mounted motor and enclosed impeller. Applications include spray booths, rust-proofing systems and car washes.



# VCRO balanced thrust pumps



## OPEN IMPELLER

VCRO impellers are designed to provide high efficiencies. They are hydraulically and statically balanced, and have low submergence requirements.

## BEARING/STUFFING BOX OPTIONS

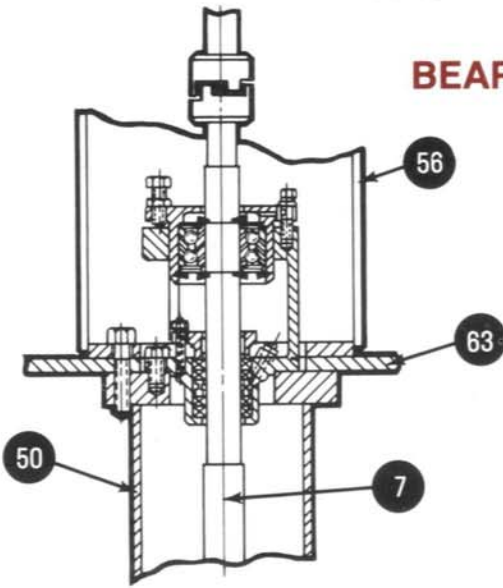

Elevated thrust Bearing and stuffing box with packing

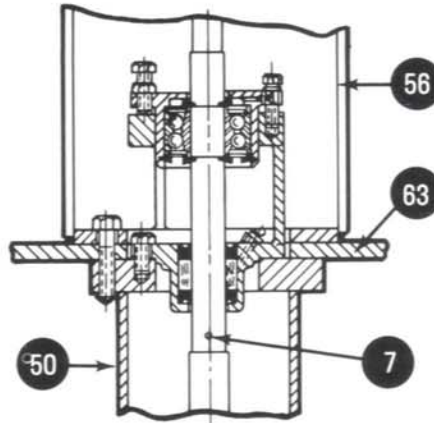

Elevated thrust bearing and stuffing box with grease seals

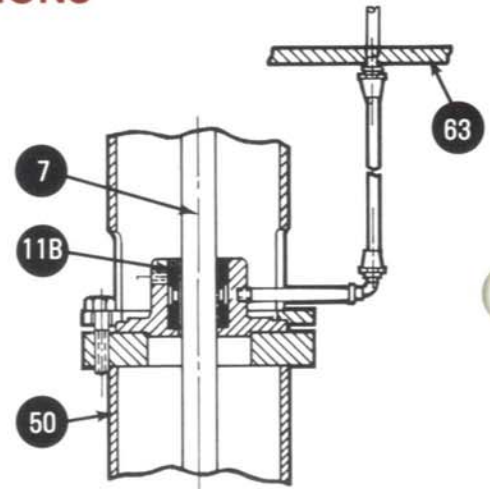

Intermediate guide bearing with extended liquid lube line

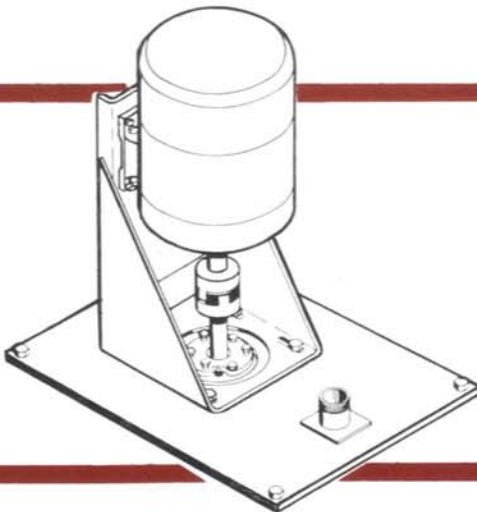

## OPTIONAL MOTOR MOUNT

This optional motor mount is available for any Buffalo VCRO Pump. It permits the use of standard foot mounted motors.

# Materials of Construction

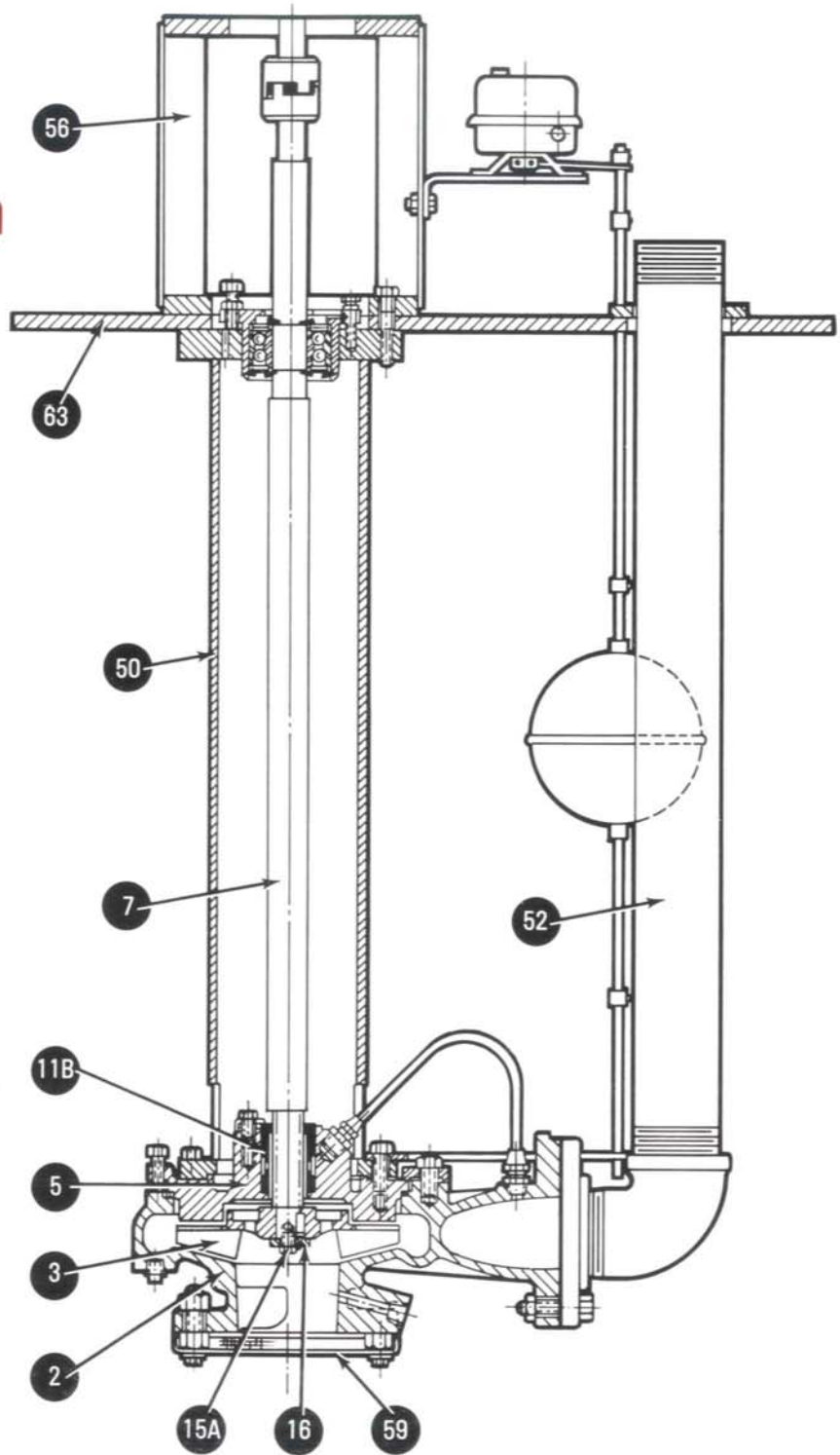

## Special Materials

In addition to the standard materials of construction, VCRO Pumps are available in Alloy 20, nickel, Monel and cast steel.

PART NO.	PART NAME	CAST IRON	316 FITTED	ALL 316
2	CASING	CAST IRON	CAST IRON	316SS
3	IMPELLER	CAST IRON	316SS	316SS
5	CASING COVER	CAST IRON	CAST IRON	316SS
7	SHAFT	STEEL	316SS	316SS
11B	BEARING BUSHING	CARBON GRAPHITE		
15A	IMPELLER LOCK SCREW	18-8 STAINLESS	316SS	316SS
16	IMPELLER NUT WASHER	STEEL	316SS	316SS
50	CONNECTING PIPE	STEEL		316SS
52	DISCHARGE PIPE	STEEL		316SS
56	MOTOR STAND	STEEL		
59	STRAINER	316SS		316SS
63	COVER PLATE	STEEL		STEEL OR 316SS



# VCR0 balanced thrust pumps performance / open impeller

1750 rpm

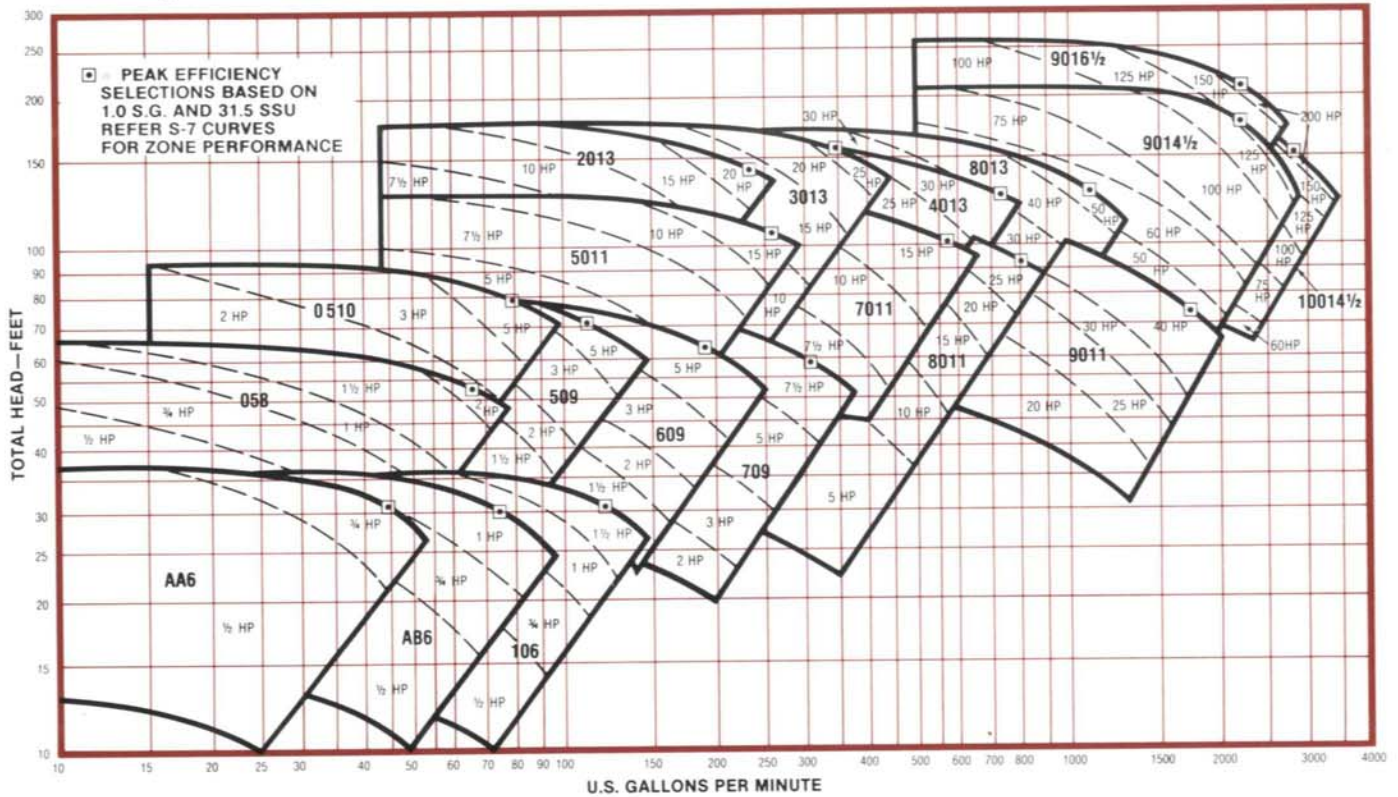

1150 rpm

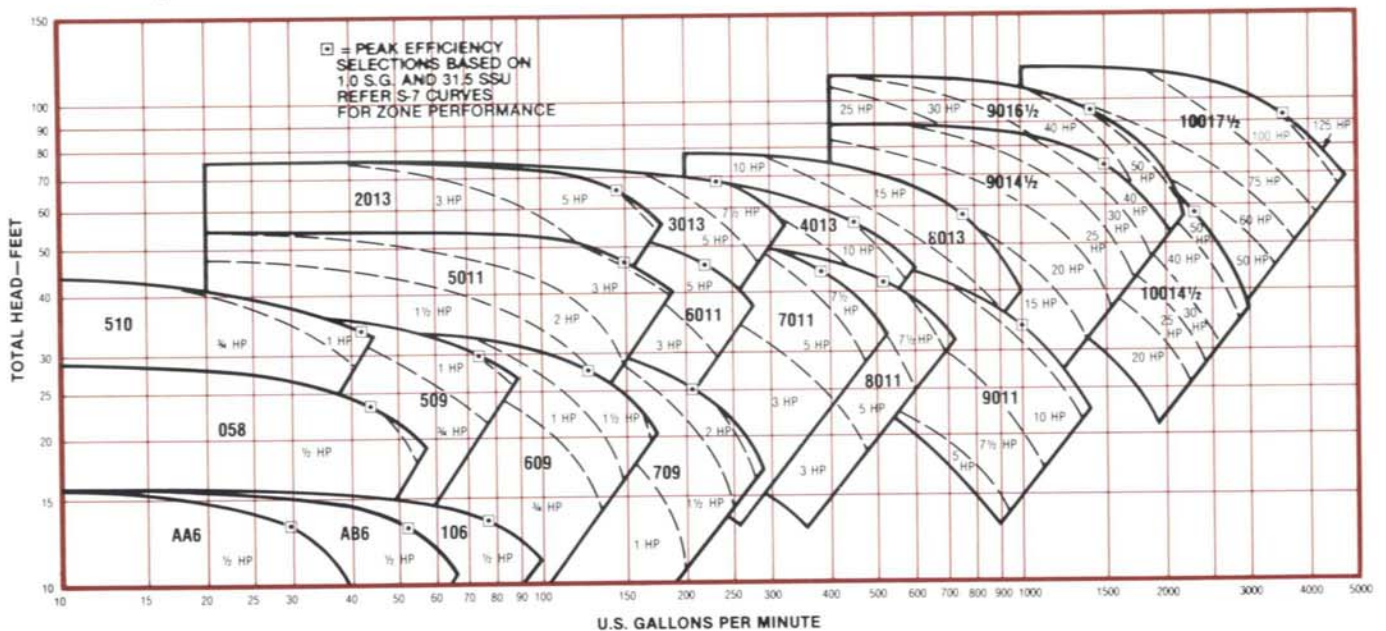

# VCRO pump dimensions

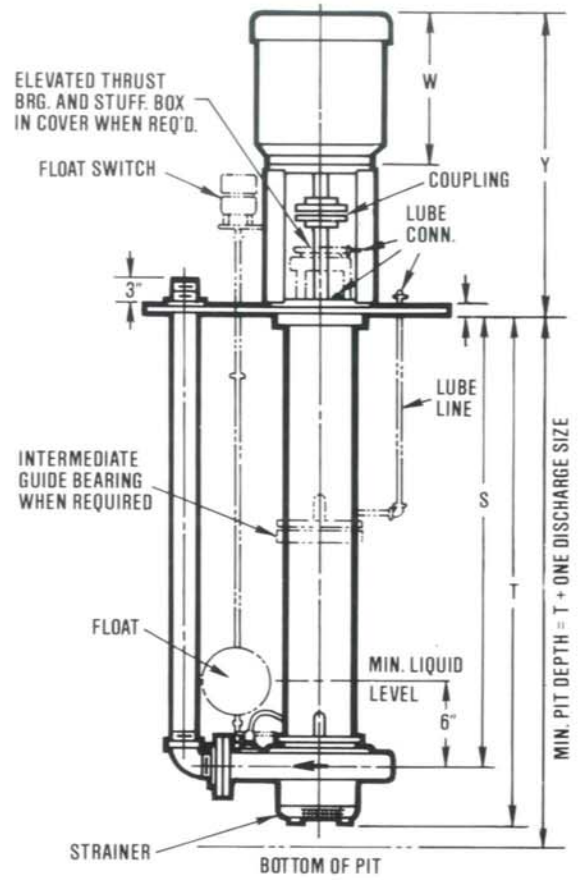
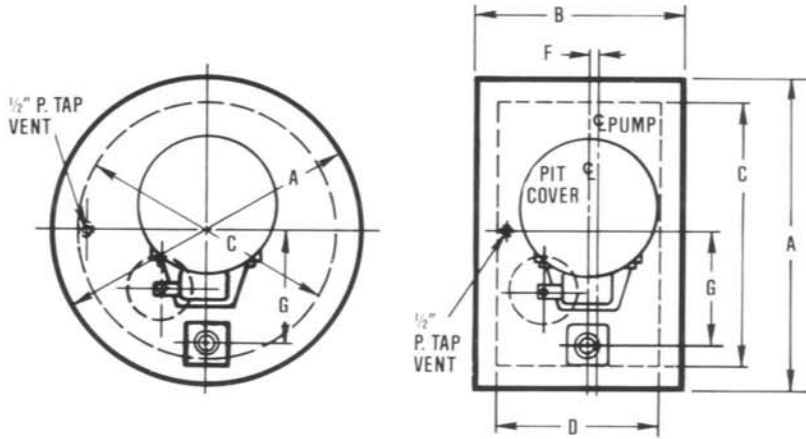

## DIMENSIONS - SIMPLEX AND DUPLEX PUMPS

PUMP SIZE	SHAFT GROUP	DISCH. SIZE	SIMPLEX COVERPLATE SIZES										DUPLEX COVERPLATE SIZES*																
			ROUND COVERS					RECTANGULAR COVERS					WITHOUT MANHOLE					WITH MANHOLE											
			STD.	PIT OPEN.				STD.	PIT OPEN.				MIN. PIT		COVERPLATE		THICKNESS		MINI. PIT		COVERPLATE		THICKNESS						
			A	C	G	A	B	C	D	F	G	THICKNESS	□	○	□	○	THICKNESS	□	○	□	○	THICKNESS	□	○	THICKNESS	□	○		
AA6	VC1	1	25	21	8 1/2	24	18	20	14	1 1/4	8	1/2	AA6	1/2	24 x 38	44	28 x 42	48	1/2	38 x 39	50	42 x 43	54	1/2	48 x 48	54	1/4	108 x 108	120
AB6	VC1	1 1/2	25	21	8 1/4	24	18	20	14	1 1/4	7 3/4	1/2	AB6	1/2	24 x 38	44	28 x 42	48	1/2	38 x 39	50	42 x 43	54	1/2	48 x 48	54	1/4	108 x 108	120
106	VC1	2	25	21	8 3/4	24	18	20	14	1 1/4	7 3/4	1/2	106	1/2	24 x 38	44	28 x 42	48	1/2	38 x 39	50	42 x 43	54	1/2	48 x 48	54	1/4	108 x 108	120
058	VC2	1	31	27	12	30	20	26	16	0	11 1/4	1/2	058	3/4	30 x 42	52	34 x 46	56	3/4	42 x 45	56	46 x 49	60	3/4	60 x 60	60	1/4	120 x 120	132
0510	VC2	1	31	27	12	30	20	26	16	0	11 1/4	1/2	0510	3/4	30 x 42	52	34 x 46	56	3/4	42 x 45	56	46 x 49	60	3/4	60 x 60	60	1/4	120 x 120	132
509	VC2	1 1/2	31	27	11 1/4	30	20	26	16	0	10 3/4	1/2	509	3/4	30 x 42	52	34 x 46	56	3/4	42 x 45	56	46 x 49	60	3/4	60 x 60	60	1/4	120 x 120	132
609	VC2	2	31	27	11 1/4	30	20	26	16	0	10 3/4	1/2	609	3/4	30 x 42	52	34 x 46	56	3/4	42 x 45	56	46 x 49	60	3/4	60 x 60	60	1/4	120 x 120	132
5011	VC2	1 1/2	31	27	12	30	20	26	16	0	11 1/4	1/2	5011	3/4	30 x 42	52	34 x 46	56	3/4	42 x 45	56	46 x 49	60	3/4	60 x 60	60	1/4	120 x 120	132
709	VC2	3	36	32	11 1/4	36	26	32	22	3/4	11 1/4	1/2	709	3/4	36 x 54	65	40 x 58	69	3/4	51 x 54	65	55 x 58	69	3/4	66 x 66	69	1	120 x 120	132
6011	VC2	2	36	32	11	36	26	32	22	3/4	10 3/4	1/2	6011	3/4	36 x 54	65	40 x 58	69	3/4	51 x 54	65	55 x 58	69	3/4	66 x 66	69	1	120 x 120	132
7011	VC2	3	36	32	13 1/4	36	26	32	22	3/4	12 3/4	1/2	7011	3/4	36 x 54	65	40 x 58	69	3/4	51 x 54	65	55 x 58	69	3/4	66 x 66	69	1	120 x 120	132
2013	VC2	1 1/2	36	32	9 3/4	36	26	32	22	3/4	8 3/4	1/2	2013	3/4	36 x 54	65	40 x 58	69	3/4	51 x 54	65	55 x 58	69	3/4	66 x 66	69	1	120 x 120	132
3013	VC3	2	36	32	11	36	26	32	22	3/4	10 3/4	1/2	3013	3/4	36 x 54	65	40 x 58	69	3/4	51 x 54	65	55 x 58	69	3/4	66 x 66	69	1	120 x 120	132
4013	VC3	3	36	32	13 1/4	36	26	32	22	3/4	12 3/4	1/2	4013	3/4	36 x 54	65	40 x 58	69	3/4	51 x 54	65	55 x 58	69	3/4	66 x 66	69	1	120 x 120	132
8011	VC2	4	42	38	13	40	30	36	26	0	12	1/2	8011	3/4	40 x 62	74	44 x 66	78	1/2	55 x 62	74	59 x 66	78	1/2	78 x 78	90	1	114 x 114	120
8013	VC3	4	42	38	13	40	30	36	26	0	12	1/2	8013	3/4	40 x 62	74	44 x 66	78	1/2	55 x 62	74	59 x 66	78	1/2	78 x 78	90	1	114 x 114	120
9011	VC3	6	42	38	14 1/2	40	30	36	26	0	13 1/2	1/2	9011	3/4	40 x 62	74	44 x 66	78	1/2	55 x 62	74	59 x 66	78	1/2	78 x 78	90	1	114 x 114	120
9014 1/2	VC4	6	51	49	19 3/4	49	33	45	29	1 1/2	18 3/4	3/4	9014 1/2	1 1/4	49 x 68	84	55 x 74	90	1 1/4	64 x 68	84	70 x 74	90	1 1/4	108 x 108	120	1 1/4	132 x 132	144
9016 1/2	VC4	6	55	53	20 3/4	55	35	51	31	1 1/2	21 3/4	3/4	9016 1/2	1 1/4	55 x 72	90	61 x 78	96	1 1/4	70 x 72	90	76 x 78	96	1 1/4	108 x 108	120	1 1/4	132 x 132	144
10014 1/2	VC4	8	58	56	21 1/4	58	38	54	34	2 1/4	22	3/4	10014 1/2	1 1/4	58 x 78	96	64 x 84	102	1 1/4	73 x 78	96	79 x 84	102	1 1/4	108 x 108	120	1 1/4	132 x 132	144
10017 1/2	VC5	8	64	62	25 1/4	63	40	59	36	1 3/4	24 1/2	3/4	10017 1/2	1 3/4	63 x 82	104	69 x 88	110	1 3/4	78 x 82	104	84 x 88	110	1 3/4	90 x 90	110	1 1/2	132 x 132	132

\*Each simplex pump when used on minimum size duplex coverplate must use standard size simplex rectangular coverplate.

\*1. Sizes are based on coverplate supported around the entire perimeter with a minimum of 2" overhang beyond pit or tank opening based on 1/2" maximum size anchor bolts. Larger anchor bolts require increased size coverplates.

## MOTOR DATA

FRAME	W	VC1,2,3 Y	VC4 Y	VC5 Y	FRAME	W	VC1,2,3 Y	VC4 Y	VC5 Y
143HP	11 1/4	25 1/4			324HP	28 1/4	44 1/4	46 1/2	49 1/4
145HP	12 1/4	26 1/4			326HP	28 1/4	44 1/4	46 1/2	49 1/4
182HP	15 1/4	29 1/4			364HP	30 3/4	46 1/4	48 1/4	52 1/4
184HP	15 1/4	29 1/4			365HP	30 3/4	46 1/4	48 1/4	52 1/4
213HP	18 1/4	32 1/4			404HP	34 1/4			56
215HP	18 1/4	32 1/4			405HP	34 1/4			56
254HP	23	39 1/4			444HP	39 3/4			60 1/4
256HP	23	39 1/4			445HP	39 3/4			60 1/4
284HP	26 1/4	43 1/4	45 1/4	48 1/4	628HP	54			75 1/4
286HP	26 1/4	43 1/4	45 1/4	48 1/4					

## PUMP LENGTH\*\* (VC-1, VC-2 & VC-3)

NO INTERMEDIATE GUIDE BEARING									
S	20 1/4	26 1/4	32 1/4	38 1/4	44 1/4	50 1/4	56 1/4	62 1/4	68 1/4
T*	25 1/2	31 1/2	37 1/2	43 1/2	49 1/2	55 1/2	61 1/2	67 1/2	73 1/2
ONE INTERMEDIATE GUIDE BEARING									
S	74 1/2	80 1/2	86 1/2	92 1/2	98 1/2	104 1/2	110 1/2	116 1/2	
T*	79 1/4	85 1/4	91 1/4	97 1/4	103 1/4	109 1/4	115 1/4	121 1/4	

\* Except 9011 add 2 inches

## PUMP LENGTH\*\* (VC-4 & VC-5)

NO INTERMEDIATE GUIDE BEARING									
S	16	22	28	34	40	46	52	58	64
T	24	30	36	42	48	54	60	66	72
ONE INTERMEDIATE GUIDE BEARING									
S	70 1/4	76 1/4	82 1/4	88 1/4	94 1/4	100 1/4	106 1/4	112 1/4	
T*	78 1/4	84 1/4	90 1/4	96 1/4	102 1/4	108 1/4	114 1/4	120 1/4	

\*\*Greater pump lengths (T) available on special order.



## SALES REPRESENTATIVES

ALBANY, NY  
ALBUQUERQUE, NM  
ALLENTOWN, PA  
ATLANTA, GA  
BALTIMORE (SEVERNA PARK), MD  
BIRMINGHAM, AL  
BOSTON (WAKEFIELD), MA  
BUFFALO (ORCHARD PARK), NY  
CHICAGO (WHEELING), IL  
CINCINNATI, OH  
CLEVELAND, OH  
COLUMBUS, OH  
DALLAS (RICHARDSON), TX  
DENVER (ENGLEWOOD), CO  
DES MOINES, IA  
DETROIT (FARMINGTON HILLS), MI  
FLORIDA (MIAMI) FL  
(TAMPA)  
(JACKSONVILLE)  
GREENSBORO, NC  
GREENVILLE, SC  
HARTFORD (AVON), CT  
HOUSTON, TX  
INDIANAPOLIS, IN  
KANSAS CITY, MO  
KNOXVILLE, TN  
LOS ANGELES (SANTA FE SPRINGS), CA  
LOUISVILLE, KY  
MEMPHIS, TN  
MILWAUKEE, WI  
MINNEAPOLIS (BLOOMINGTON), MN  
NEW ORLEANS, LA  
NEW YORK (E. NORWALK, CT)  
NORTHERN NEW JERSEY (PLUCKEMIN, NJ)  
OKLAHOMA CITY, OK  
PHILADELPHIA (WYNNEWOOD), PA  
PHOENIX, AZ  
PITTSBURGH, PA  
RICHMOND, VA  
ROCHESTER, NY  
ST. LOUIS, MO  
SALT LAKE CITY, UT  
SAN ANTONIO, TX  
SAN FRANCISCO (EMERYVILLE), CA  
SEATTLE (BELLEVUE, WA)  
SYRACUSE, NY  
TOLEDO (PERRYSBURG), OH  
TULSA, OK  
WASHINGTON, D.C.  
(ROCKVILLE, MD)  
(ALEXANDRIA, VA)

**In Canada:**  
CALGARY, ALTA.  
EDMONTON, ALTA.  
HAMILTON, ONT.  
KITCHENER, ONT.  
MONTREAL, QUE.  
OTTAWA, ONT.  
SAINT JOHN, N.B.  
SARNIA, ONT.  
SASKATOON, SASK.  
TORONTO, ONT.  
VANCOUVER, B.C.  
WINNIPEG, MAN.

**In Mexico:**  
GUADALAJARA, JAL.  
MEXICO CITY, D.F.  
MONTERREY, N.L.

# Other Buffalo Pumps

## CRE/CRO STANDARD DIMENSION PUMPS

Buffalo Standard Dimension 4-Way Pumps are designed to operate with reduced axial and radial loads for long maintenance-free service in the chemical process and allied industries. 21 styles. Capacities to 5000 gpm. Pressures to 300 psi. Bulletin 903.

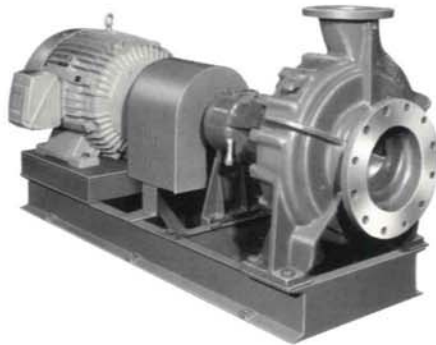
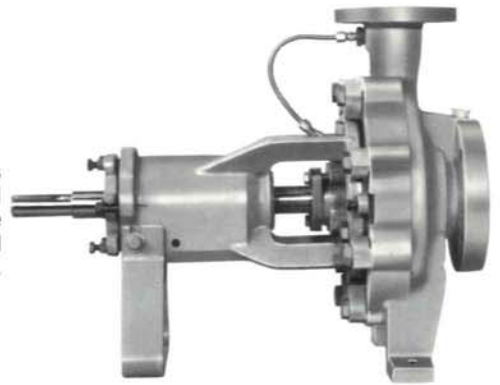

## PAPER STOCK PUMPS

These compact paper stock and process pumps are engineered for high efficiency, reliable operation, low maintenance and long service life. Capacities to 11,000 gpm. Heads to 260 feet. Pressures to 150 psi. Stock handling capacity to 6%. Bulletin - 950.

## Buffalo "SH" SOLIDS HANDLING PUMPS

These industrial solids handling pumps are available in horizontal, vertical non-submerged, vertical submerged and close-coupled models. Sizes to handle up to 4" solids. Capacities to 6000 gpm. Pressures to 100 psi. Heads to 225'. Bulletin 964.

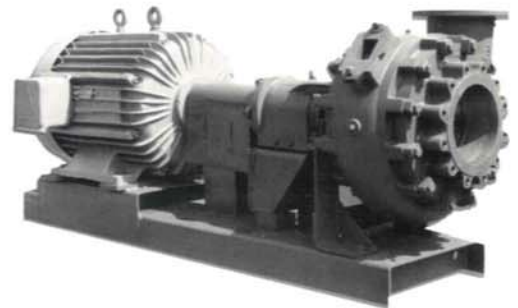

## CR-AV VORTEX PUMPS

Designed to handle abrasive slurries and solids, this line of vortex type pumps features an adjustable replaceable vane impeller. Adjustable feature provides modification of pump output and compensation for wear. One impeller hub size and three vane lengths provide impeller diameters from 7" to 13" at 1/2" increments. Capacities to 2000 gpm. Heads to 190 ft. Bulletin 902. Patent Pending.

# buffalo pumps



An Ampco-Pittsburgh Company

BUFFALO, NEW YORK 14240-0985

